

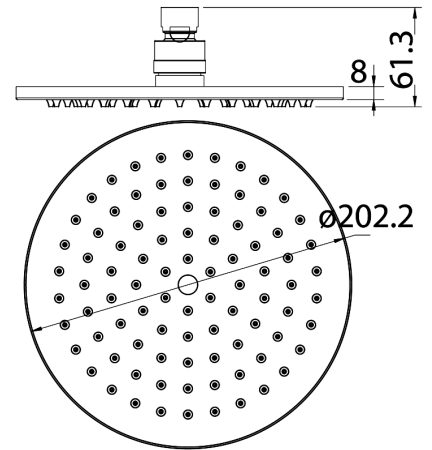

PRB1056N - Chrome



PRB1056N-BN - Brushed Nickel



PRB1056N-B - Matt Black



PRB1056N-BG - Brushed Gold



PRB1056N-GM - Gunmetal



CORA SHOWER HEAD

PRB1056N*

FINISH: See Above

MATERIAL: Brass

WORKING PRESSURE: 150-500kpa

OPERATING TEMPERATURE: 1°C—80°C

WELS LICENCE: 0175

WELS: 3 Star 8.5L Per Min, Reg No. S15565

Maintenance and Care

- Do not use harsh detergents or products that contain chloride & halides.
- Do not use abrasive, cream or citrus based cleaners or hydrochloric acid.
- Surface should be cleaned only with a mild detergent that must be rinsed off.
- It is suggested to only clean with warm water and a soft cloth.
- Damage caused by the wrong cleaning methods used will void warranty.

Warranty Coloured Finish:

2 Years Matt Black. **5 Years** other finishes replacement product & parts.