

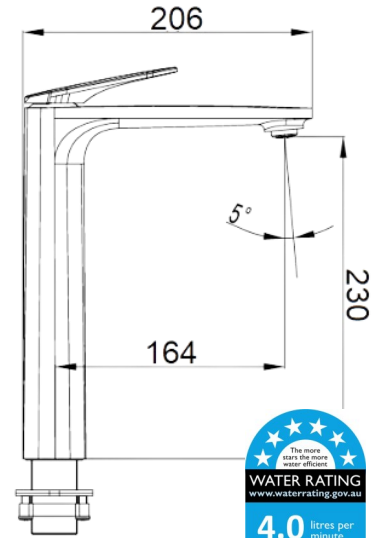

HYB168-202 - Sulu II High Rise
Basin Mixer - Chrome



HYB168-201BG - Sulu II High Rise
Basin Mixer - Brushed Gold



HYB168-201BN - Sulu II High Rise
Basin Mixer - Brushed Nickel



HYB168-201GM - Sulu II High Rise
Basin Mixer - Gunmetal



HYB168-201MB - Sulu II High Rise
Basin Mixer - Matt Black



SULU II BASIN HIGH RISE MIXER

HYB168-202*

FINISH: See Above

MATERIAL: Brass

WORKING PRESSURE: 150-500kpa

OPERATING TEMPERATURE: 1°C—70°C

WELS LICENCE: 0175

WELS: 6 Star, 4.0L/Min Reg no. T45064

CARTRIDGE TYPE: 35mm Cartridge



LEAD FREE

Maintenance and Care

- Do not use harsh detergents or products that contain chloride & halides.
- Do not use abrasive, cream or citrus based cleaners or hydrochloric acid.
- Surface should be cleaned only with a mild detergent that must be rinsed off.
- It is suggested to only clean with warm water and a soft cloth.
- Damage caused by the wrong cleaning methods used will void warranty.

Coloured Finish:

2 Years Matt Black. **5 Years** other finishes replacement product & parts.

It is highly recommended an application of sealant at the base of the mixer to ensure a water tight seal.